

FLAVIA



CONFORME
EUROPEA
EN 14183

CONFORME
D. Lgs
81/2008 Art. 113



Sgabello pieghevole:

Sgabello pieghevole con una struttura completamente in alluminio, con ampi gradini antiscivolo da mm 200 di profondità e parapetto.

Caratteristiche:

- Montanti rettangolari da mm 84x25
- Gradini piani con superficie antiscivolo da mm 200
- Piano di calpestio da mm 400
- Parapetto pieghevole
- N.2 zoccolini nella parte anteriore
- N.2 tappi antisdrucchiolo nella parte posteriore
- Portata kg 150
- Normativa Europea 14183

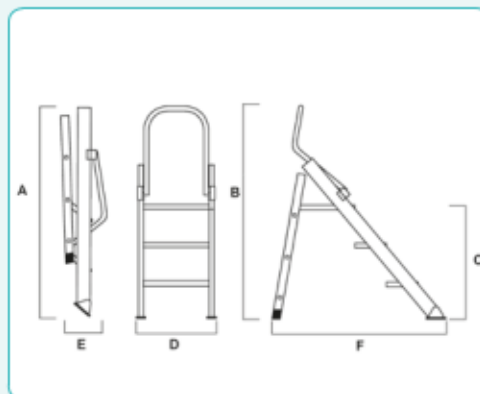

• Flavia chiusa

CODICE	A(m)	B(m)	C(m)	D(m)	E(m)	F(m)	Kg	N.Gr.*	M ³
A16FLA2	0,97	1,13	0,49	0,49	0,28	0,88	8,50	2	0,13
A16FLA3	1,32	1,38	0,74	0,49	0,28	1,15	10,50	3	0,18
A16FLA4	1,70	1,62	0,98	0,49	0,28	1,36	12,50	4	0,23

*Il numero dei gradini comprende la piattaforma